

THIS DRAWING IS CONFIDENTIAL AND IS SUPPLIED ON THE CONDITION THAT IT SHALL NOT BE LENT OR COPIED OR DISCLOSED TO ANY OTHER PERSON, OR USED FOR ANY OTHER PURPOSE WITHOUT THE WRITTEN CONSENT OF APEKS MARINE EQUIPMENT LTD.



Apeks Marine Equipment Ltd.

Neptune Way, Blackburn, BB1 2BT
 Telephone : 0(44) 1254 69 22 00
 Fax : 0(44) 1254 69 22 11



3rd Angle Projection

IF IN DOUBT ASK!

Designed By:

Lee Holt

Drawn By:

Lee Holt

18/10/06

Re-Drawn By:

Modified By:

Checked By:

Andy Davis

18/10/06

Issued By:

Lee Holt

18/10/06

GENERAL TOLERANCE: ± 0.1

ANGULAR TOLERANCE: ± 1°

Unless Stated Otherwise

All diameters are to be concentric to: 0.2 T.I.R
 Remove all burrs and break sharp edges to a max. of: 0.25 mm.

All threads Class 'B' unless stated otherwise.

SURFACE ROUGHNESS

RA Shown 1.6
 By Micro Meters: ✓
 Unless Stated Otherwise
 To be measured at a cutoff 0.8 mm and a Range of 5

NOTE:

- ALL DIMENSIONS ARE AFTER TREATMENT & FINISH. THIS IS A FINISHED COMPONENT DRAWING.
- CHROME PLATED COMPONENTS MUST BE INSPECTED USING PRE-PLATING GAUGES ON ALL EXTERNAL THREADS PRIOR TO TREATMENT.

Scale: 1:2

Do Not Scale Drawing

All Dimensions in Millimetres Unless Stated Otherwise

Paper Size: A3

ITEM NO.	PartNo	Description:	QTY:
1	AP1484	Environmental Endcap	1
2	AP1482/1	Hydrostatic Diaphragm.	1
3	AP1483	Hydrostatic Transmitter	1
4	AP1474	Spring Adjuster	1
5	AP1475	MP Adj Spring	1
6	AP5725	Logo Ring	1
7	AP1473/1	BP Diaphragm Clamp	1
8	AP1476	Spring Carrier	1
9	AP1478	Diaphragm	1
10	AP1479	Valve Lifter	1
11	AP5105	Tek3 first stage RH Body	1
12	AP1419	HP Valve	1
13	AP1415	Spring	1
14	AP1299	BS006 'O' Ring	1
15	AP1410	BS013 'O' Ring	1
16	AP1300	BS151-16 'O' Ring	1
17	AP5202	HP Balance Plug	1
18	AP5106	Technical Decal	1
19	AP1408	3/8" UNF Blanking Plug	2
20	AP1409	BS011 'O' Ring	2
21	AP1259-38	3/8" UNF Red Moss Cap	1
22	AP1413	7/16" UNF Blanking Plug	1
23	AP1445	BS012 'O' Ring	1
24	AP1446	Distance Piece	1
25	AP0211	DIN Hand Wheel Assembly	1

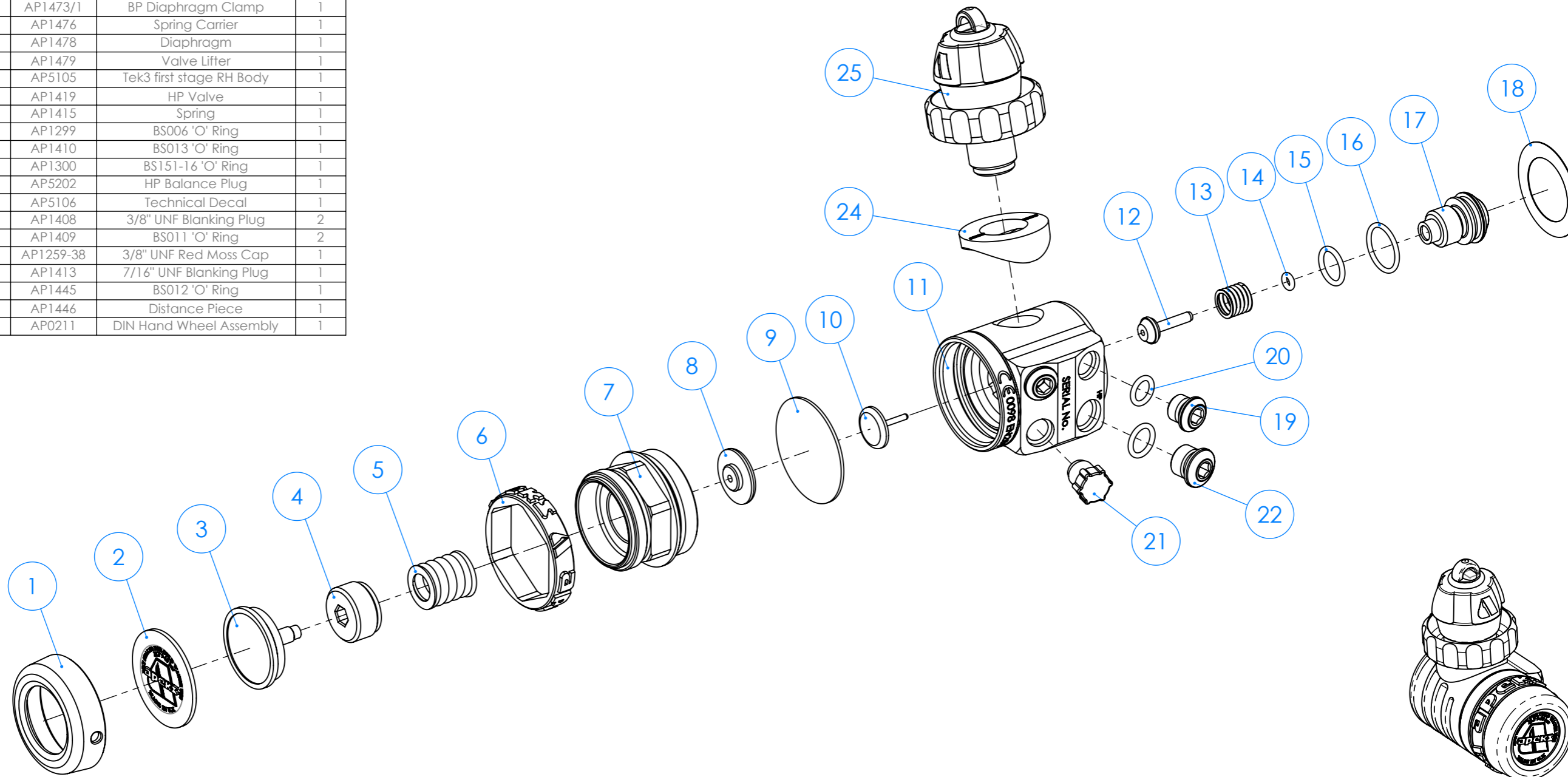

Drawing Standard BSI

MATERIAL: See BOM

Colour: Colour

Spec.

Weight: (g)

FINISH: Bright Chrome

Volume: (mm3)

Spec. Cu, Ni b, Cr

Surface Area: (mm2)

TREATMENT: Vibrated

Project: PRJ-0266

Spec.

Notes: UNLESS OTHERWISE SPECIFIED

① Dimensions and Characteristics marked with this symbol will be inspected by Apeks Marine Equipment as 'Critical' which is defined in BS6001x

② Dimensions and Characteristics marked with this symbol will be inspected by Apeks Marine Equipment as 'Major' which is defined in BS6001x

ISSUED BY: CHANGE NUMBER: ISSUED DATE: Issue Number:

Title:

TEK3 RH 1st stage Assy

NATO Stock Number:

N/A

Responsible Authority & Master Drawing No:

Apeks

Apeks Drawing No:

AP0366-1-R

SHEETS: 1 OF 1

Issue No: Status:

1.0

Released